

ENGINE MECHANISM CHAINS(TIMING CHAINS)

TRANSMISSION CHAIN SERIES

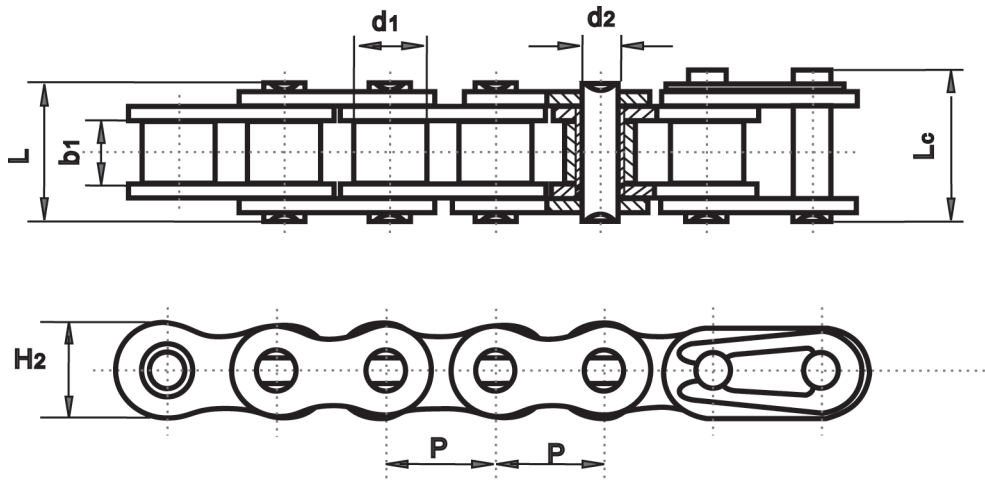

| Chain No. | Pitch | Roller diameter | Pin diameter | Width between inner plates | Pin length | | Inner plate depth | Ultimate tensile strength | Weight approx. |
|-----------|-------|-----------------|--------------|----------------------------|------------|---------|-------------------|---------------------------|----------------|
| | P | d1(max) | d2(max) | b1(min) | L(max) | Lc(max) | h2(max) | Q | q |
| | mm | mm | mm | mm | mm | mm | mm | KN | kg/m |
| 10 | 3.175 | 1.70 | 1.16 | 1.60 | 4.45 | 5.05 | 2.90 | - | 0.039 |
| 25 | 6.35 | 3.30 | 2.31 | 3.10 | 7.70 | 8.45 | 5.90 | 3.5 | 0.13 |
| 25H | 6.35 | 3.30 | 2.31 | 3.18 | 9.00 | 9.45 | 5.90 | 4.8 | 0.16 |
| 25HT | 6.35 | 3.30 | 2.31 | 3.18 | 9.00 | - | 5.90 | 6.0 | 0.16 |
| 25SH | 6.35 | 3.30 | 2.01 | 3.18 | 9.00 | 9.45 | 5.90 | 5.2 | 0.17 |
| 219H | 7.774 | 4.59 | 3.01 | 5.00 | 12.0 | 12.70 | 7.60 | 6.6 | 0.27 |
| 219HT | 7.774 | 4.59 | 3.01 | 4.60 | 12.15 | 12.90 | 7.60 | 10.0 | 0.30 |
| 219TS | 7.774 | 4.59 | 2.62 | 5.00 | 11.85 | - | 7.60 | 8.8 | 0.27 |
| 270H | 8.50 | 5.00 | 3.28 | 4.75 | 13.3 | - | 8.60 | 9.8 | 0.39 |
| 35T | 9.525 | 5.08 | 3.58 | 4.68 | 12.15 | 13.15 | 8.70 | 8.0 | 0.27 |
| T8F | 8.00 | 4.77 | 3.28 | 5,72 | 13.90 | - | 7.50 | 10.2 | 0.39 |
| T3F | 9.525 | 6.00 | 4.50 | 9.50 | 18.60 | - | 9.30 | 11.8 | 0.61 |